

Shaft Mounted Clutches/Power-On Brakes – Type SLB and SOB

The SLB and SOB series are shaft mounted clutch/power-on brake packages that are used to couple two parallel or in-line shafts.

The clutch/brake package combines the features of our model SL or SO with an FB into one unit for easy installation.

The clutch armature hub accommodates a pulley, gear, sprocket, etc., to transmit torque to the second shaft. The brake is used to stop or hold the load.

The clutch/brake package is shaft mounted and retained by a loose-fitting pin or bracket through the anti-rotation tab.



SLB and SOB

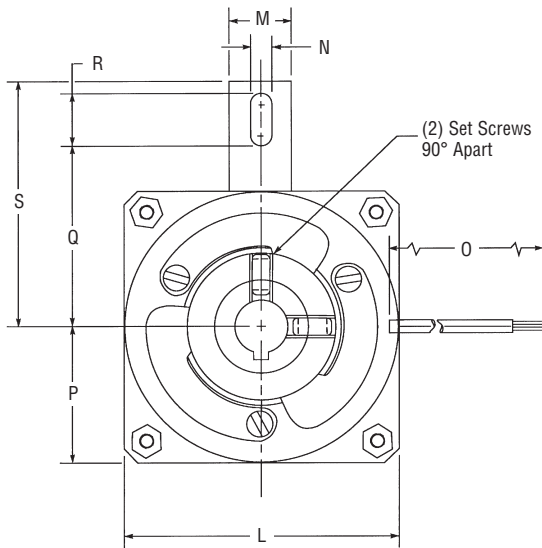

Customer Shall Maintain:

a loose-fitting pin through the anti-rotation tab to prevent pre-loading the bearings; initial air gap setting of .008-.020 inches on the brake side. On SOB models concentricity between the shafts within .005 T.I.R.

SLB

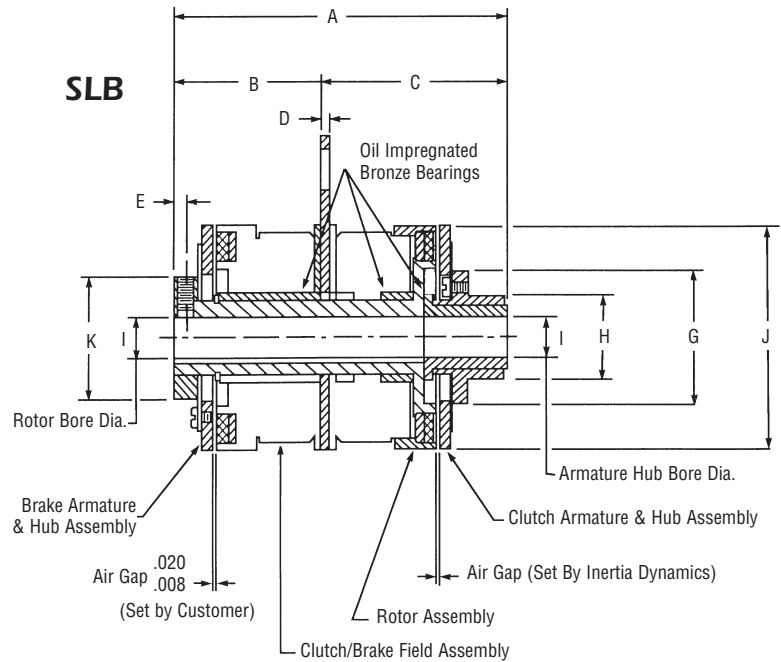

SOB

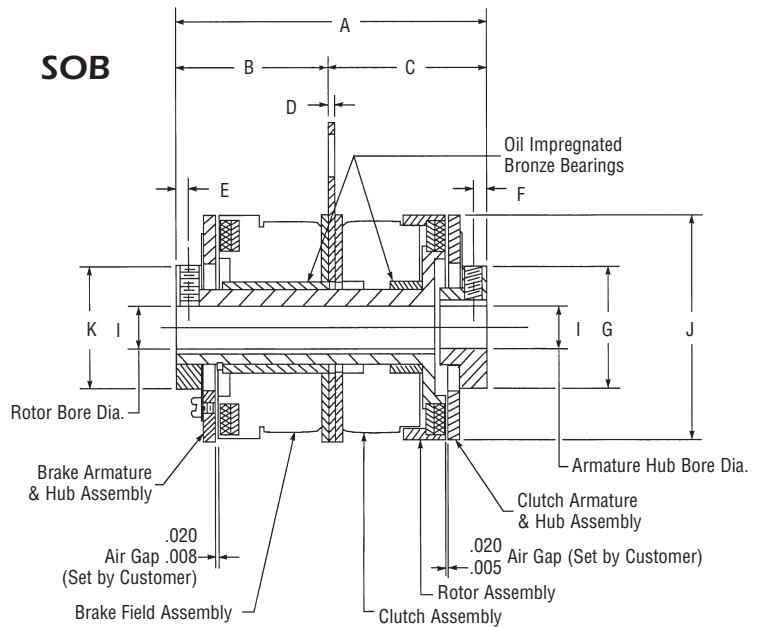

Shaft Mounted Clutches/Power-On Brakes – Type SLB and SOB

Mechanical

MODEL NO.	STATIC TORQUE LB. – IN.	INERTIA LB. – IN. ²		WGT. OZ.
		ROTOR	ARM & HUB	
SLB11 SOB11	6	.0089	.0029 .0024	7
SLB17 SOB17	15	.098	.0360 .0310	22
SLB19 SOB19	25	.129	.0470 .0420	25
SLB22 SOB22	50	.295	.0790 .0700	45
SLB26 SOB26	80	.660	.2920 .3200	60

Electrical

MODEL NO.	90 VDC		24 VDC		12 VDC	
	AMPS	OHMS	AMPS	OHMS	AMPS	OHMS
SLB11 SOB11	.047	1930	.198	121	.447	26.8
SLB17 SOB17	.066	1369	.289	83	.561	21.4
SLB19 SOB19	.074	1213	.322	74.4	.574	20.9
SLB22 SOB22	.079	1140	.322	74.6	.628	19.1
SLB26 SOB26	.088	1024	.350	67.1	.667	18.0

Lead wire is UL recognized style 1213, 1015 or 1429, 22 gage.
Insulation is .050" O.D. on 11 unit; .064" or .095" O.D. on all other units.

Dimensions

MODEL NO.	A MAX.	B REF.	C NOM.	D MAX.	E NOM.	F *	G MAX.	H **	I NOM.	J MAX.	K MAX.	L MAX.	M MAX.	N MIN.	O ± .5	P MAX.	Q MIN.	R MIN.	S MAX.	KEYWAYS		
																				BORE	NOMINAL KEYWAY X	Y
SLB11	2.225	.974	1.229	.051	.094	.410	.700	.506	1/4 5/16	1.160	.700	1.240	.520	.140	12.00	.630	.630	.300	1.050	N.A.	SET SCREWS ONLY	
SOB11	1.970	.974	.983	.051	.094	.094	.700	–	1/4 5/16	1.160	.700	1.240	.520	.140	12.00	.630	.630	.300	1.050	N.A.	SET SCREWS ONLY	
SLB17	2.855	1.245	1.590	.066	.114	.390	1.207	.629	1/4 5/16 3/8	1.780	1.207	1.960	.520	.190	12.00	.990	1.100	.510	1.707	1/4 5/16 3/8	.0625 – .0655 .0625 – .0655 .094 – .097	.285 – .290 .347 – .352 .417 – .427
SOB17	2.608	1.245	1.340	.066	.114	.114	1.207	–	1/4 5/16 3/8	1.780	1.207	1.960	.520	.190	12.00	.990	1.100	.470	1.707	1/4 5/16 3/8	.0625 – .0655 .0625 – .0655 .094 – .097	.285 – .290 .347 – .352 .417 – .427
SLB19	2.993	1.258	1.715	.066	.114	.475	1.207	.756	5/16 3/8	2.000	1.207	1.960	.520	.190	12.00	.990	1.100	.470	1.707	5/16 3/8	.0625 – .0655 .094 – .097	.347 – .352 .417 – .427
SOB19	2.615	1.258	1.337	.066	.114	.114	1.207	–	5/16 3/8	2.000	1.207	1.960	.520	.190	12.00	.990	1.100	.470	1.707	5/16 3/8	.0625 – .0655 .094 – .097	.347 – .352 .417 – .427
SLB22	3.737	1.722	1.995	.093	.115	.450	1.453	.756	3/8 1/2	2.260	1.453	2.340	.580	.190	18.00	1.180	1.136	.480	1.832	3/8 1/2	.094 – .097 .125 – .128	.417 – .427 .560 – .567
SOB22	3.552	1.722	1.810	.093	.115	.115	1.453	–	3/8 1/2	2.260	1.453	2.340	.580	.190	18.00	1.180	1.136	.480	1.832	3/8 1/2	.094 – .097 .125 – .128	.417 – .427 .560 – .567
SLB26	4.050	1.778	2.240	.093	.150	.427	1.610	.999	3/8 1/2 5/8	2.640	1.450	2.650	.645	.190	18.00	1.335	1.730	.480	2.395	3/8 1/2 5/8	.094 – .097 .125 – .128 .1885 – .1905	.417 – .427 .560 – .567 .709 – .716
SOB26	3.677	1.815	1.842	.093	.150	.150	1.450	–	3/8 1/2 5/8	2.640	1.450	2.650	.645	.190	18.00	1.335	1.730	.480	2.395	3/8 1/2 5/8	.094 – .097 .125 – .128 .1885 – .1905	.417 – .427 .560 – .567 .709 – .716

*SLB maximum; SOB nominal.

**SLB hub O.D. ± .002; SOB hub length nominal.

NOTES:

- SLB 26 units have (3)–#8-32 tapped holes on 1.375 in. B.C. in armature hub face instead of knurl.

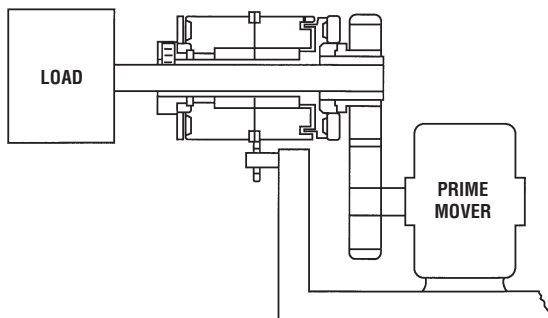

SLB

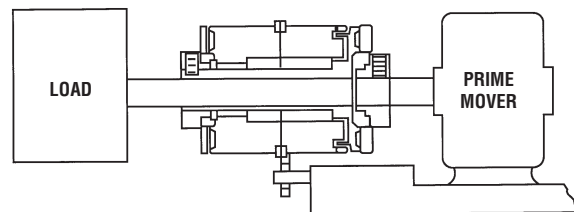

SOB

See page 3 for ordering information

Serviced By:
ELECTROMATE
Toll Free Phone (877) SERV098
Toll Free Fax (877) SERV099
www.electromate.com
sales@electromate.com

PART NUMBERING SYSTEM FOR PRODUCTS ON PAGES 3 TO 35 OF THIS CATALOG

A			A			B			B-C		D		E		F	
DIGIT	DIGIT	MODEL NO.	DIGIT	DIGIT	SIZE	DIGIT	VOLTS	DIGIT	BORE	DIGIT	DRIVE	DIGIT	CONNECTION			
1	7	FSB	0	1	001	1	90 VDC	1	1/8	1	ZERO BACKLASH	1	LEAD WIRES			
1	9	FSBR	0	2	003	2	24 VDC	2	3/16	2	HEX/SQUARE	2	SCREW TERMINALS			
2	1	FSBR (MANUAL RELEASE)	0	3	007	3	12 VDC	3	1/4	3	DYNAMIC (MANUAL RELEASE BRAKE ONLY)	3	SWITCH (MANUAL RELEASE BRAKE ONLY)			
			0	4	015	4	120 VAC	4	5/16	4	STATIC (MANUAL RELEASE BRAKE ONLY)	4	CONDUIT BOX			
			0	5	035			5	3/8	5	SPLINE					
			0	6	050			6	1/2							
			0	7	100			7	5/8							
			0	8	200			8	3/4							
0	1	SL	0	9	08			9	7/8							
0	3	BSL	1	0	11			0	1							
0	5	FL	1	1	15			11	1 1/8							
0	7	SO	1	2	17			12	1 1/4							
0	9	FO	1	3	19			13	1 3/8							
1	1	FB	1	4	22			14	1 1/2							
1	3	SLB	1	5	26											
1	5	SOB	1	6	30											
			1	7	42											
1	8	SAB	1	8	20											
			1	9	90											
			2	1	180											
			2	3	400											
			2	5	1200											

How To Order

- A. Select the model number from the product guide.
- B. Select the size of the clutch or brake.
- C. Select the voltage.
- D. Select the bore diameter.
- E. For all power-on clutches and brakes, select 1. For model FSBR and SAB-20, & 90, select 2. For model FSB spring applied brakes, select 1 or 2. For manual release brakes, select 3 or 4. For SAB-180, 400, & 1200, select 5.
- F. For all clutches and brakes, refer to the product guide and specify 1 or 2. For manual release brakes, if a switch is desired, select 3, otherwise use a 1.

Example

SL11 clutch, 24 volts, 1/4" bore
 Part No. 0110-2311
 FSB050 brake, 90 volts, 3/8" bore, Hex drive
 Part No. 1706-1521